

General

Brand	Saat Technologe
Designation	REBLER
Models	REB 120
Use	Food Processing Industry
Application	Processing of Herbs.

'Rebler', type REB-120 is designed for the separation of the leaf blade from the stalk.

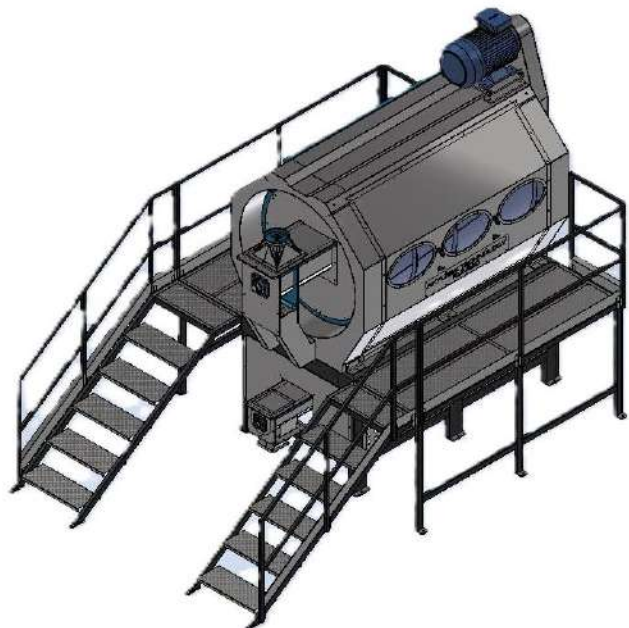

Conditions before Leaf Separation from the stalks:

Herbs to be Processed should be dry and for optimum yield it would be advised to be Pre-Cleaner.

Rebler Operation:

Processing material is dosed through the opening on the top of the Rebler from where it enters into a conical sieve where is a rotating brush that shreds the leaf on fractions according to the mesh openings.

After Rebler Operation:

After the Rebler Machine, leaves and stalks need to be separated; An Air Screen Separator and a Zig Zag Air Separator can be used to achieve the required cleanliness, and then Leaf size standardization can be used as well.

Food Grade:

Easy access to all parts of the machine.
The food-grade painted surface is sufficient for Almond Seed processing equipment. Stainless Steel surface is optional.
Food Grade Lubricants for bearings.

Rebling yield:

Rebler yield ranges from 90 to 95 %, this high variation happens due to the right conditions being provided or not and we are happy to share our experience. Please consult your sales agent.

Shipment:

If you are looking for a single machine, we provide the Cargo parameters for each machine, so the buyer can calculate the Transport cost to delivery address and we will be more than happy to assist you in this matter please feel free to consult your sales agent.

Installation:

We supply technical documents and easy-install videos to our clients for safe handling. As well as our motto is 'Plug and Play' which makes our buyer's experience much easier with Rebler.

After Sales Support:

We have 7/24 online and on-call After Sales Support Department.

For After sales parts purchasing you can go to our online saattechnologe.com or download our **App** to order your required spare part, if we have not opened an account for you, please go ahead and open your account, purchase your part and it will get it delivered to your address.

Note: Capacities may vary for different impurities, moisture contents and seed verity.

ENVIRONMENTAL CONDITIONS

Environment Indoors
Temperature from -10°C to +40°C
Altitude Up to 1 000 m

NOISE

Sound pressure level, empty 79.2 dB(A)

MODEL	REB-60	REB-120
CAPACITY up to	400 kg/hr	800 tph
MOTOR kW	up to 15	up to 30
NOISE LEVEL	75-85 dB(A)	75-85 dB(A)
Net Weight KG	750 kg	2750 (with Platform)

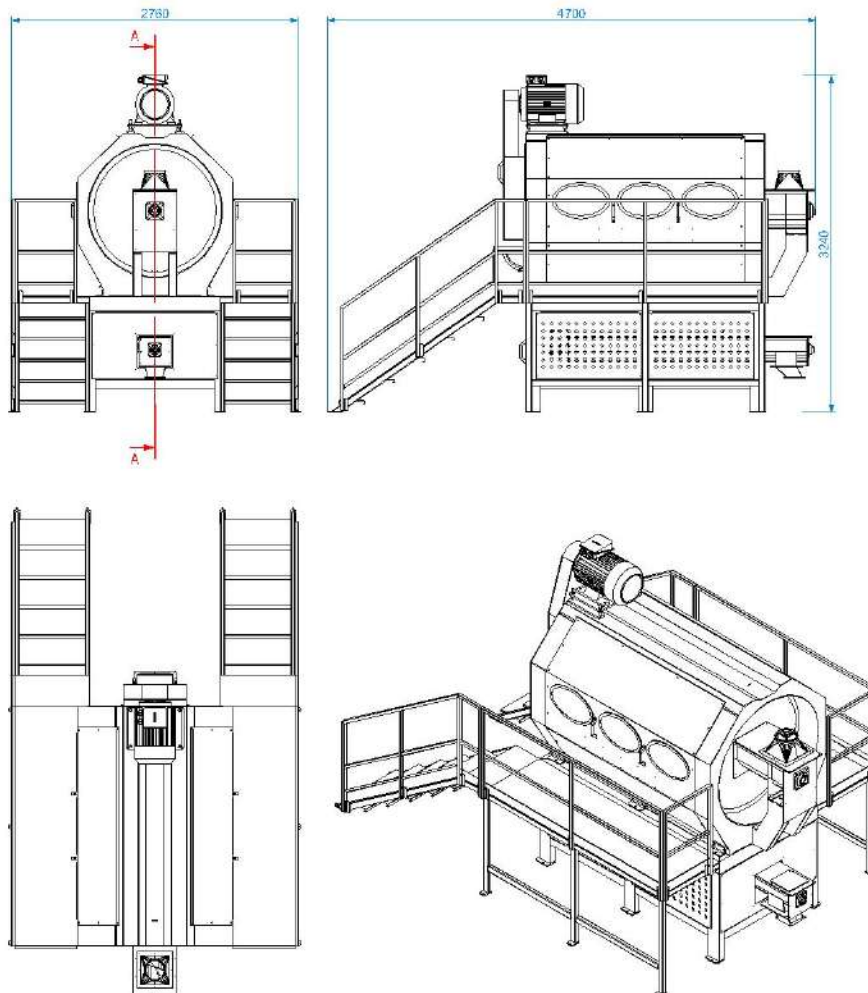

Saattechnologe.com | The right to alterations is reserved.

Saat Technologie S.R.L. | Bucharest Tower Center, 22nd Floor 15-17 Ion Mihalache Blvd.
Sector 1, Bucharest 011-171 | ROMANIA | +40 744 578 303| info@saattechnologe.com