



VIBROTARY SCREEN GRADERS

VIBROTARY SCREEN GRADERS

Saat Technologie is more than the equipment we produce. We are professionals who thrive on building creative solutions to bring your vision to life. We've been doing it since 2008. We combine the right technology with the right team to bring it all together. Our purpose is your success. You can feel confident because you have an expert at your side helping you grow into the future.

To find the right cleaning process for your business, you need a partner who understands your challenges and offers expert support. Saat Technologie has been helping customers succeed for more than 15 years. With a wide range of accurate and effective Seed Processing Equipment for grain, seed, feed and food, you can feel confident with an expert at your side to help you grow into the future.

Saat Technologie is one of the world's leading supplier of Seed processing solutions. Based on in-house technology and experience, we have the capability to carry out the full design and supply of turnkey seed processing projects. You can count on our experts throughout the entire process. When designing process plants and solutions, we use our knowhow to ensure that all parts of a plant work together seamlessly and that daily operations and subsequent maintenance run as smoothly as possible. Robust project management supports the assurance of safety that lies in our products and project execution. From the placement of your order to the end of your warranty, you have an experienced and dedicated senior project team at your side.

Gentle handling of products is key to meet your expectations for quality and hit your operational goals. Saat Technologie's equipment is specifically designed to respect your harvest and increase your production efficiency, with the ultimate goal to prepare your product for better storage.

Saat Technologie's **Vibratory** Screen Graders are designed to calibrate seeds, like grains, maize, oil seeds, legumes and similar. Saat Technologie's **Vibratory** grader is designed for dried and fine cleaned maize, pulses, coffee beans, sunflower seeds, and similar products. Flat reciprocating screens send undersized, oversized, immature and damaged seeds to a different channel. So, only useable seeds keep moving through the production process. The **Vibratory** grader can receive different moistures or densities, but it is important that products are dried and fine cleaned before entering the system.



FEATURES

The modern design of the Vibratory Screen separators allows it to achieve high quality separation at required capacities, whilst having small overall dimensions and low power consumption.

Choice of models allows to ...

- Separate Undersize frictions only
- Separate Oversize frictions only
- Separate over and undersize frictions.
- Easy Perforated Screen Changing
- Vibration Isolation with Rosta Suspensions
- Angel and Counter Weight Adjustable Vibratory Motors
- Choice of Construction Materials; Painted, Stainless Steel and or Part Stainless Steel
- Choice of Aspiration Channel separator systems.
- With or Without Rubber Ball for Blind Screen Opening
- On demand Discharge Chute Heights available

APPLICATION AREAS

- Food Processing Plants
- Separation of Smaller pieces of Seed after Seed Huller
- Separation of Larger and Smaller frictions from prime seed
- Separation of Larger frictions from prime seed
- Security Cleaning for import Seeds
- Before Bagging Separation of unwanted admixtures
- UV Light Disinfection Conveyor

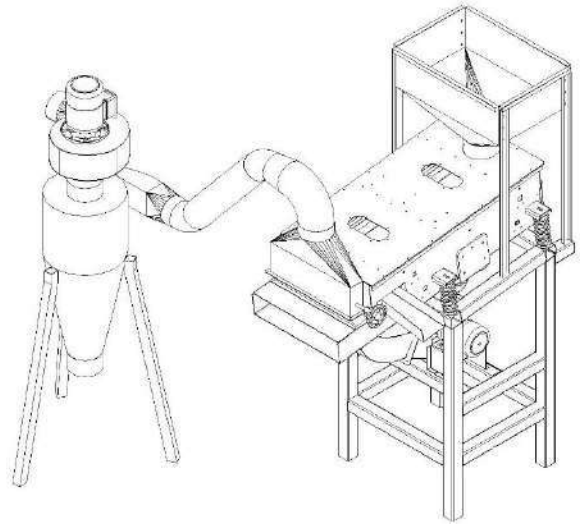

MODELS	50X80	2 L- 50X80	50X110	2 L-50X110	100x200	2 L-100X200	100X3600
Screen Layers	1	2	1	2	1	2	1
Screen Diameters in mm Width x Length	500x800	500x800	500x1100	500x1100	1000x2000	1000x2000	1000x3600
Screen Area m2	0,4	0,8	0,55	1,1	2	4	3,6
Number of Motors	1	1	1	1	2	2	2