

General

Brand	Saat Technologe
Designation	SPELT HULLER
Models	SP 250 & 500
Use	Food Processing Industry
Application	Processing of Cereal grains and other seeds.



Conditions before Hulling:

Spelt Hullers used largely at cereals such as oats, einkorn and spelt. Seed to be Hulled must be clean from all admixture for effective result.

Hulling Operation with Spelt Huller:

Hulling based on the spinning principle is a reliable and gentle process. This is proven by the good germination rate of the peeled product. The Hulling process is a gentle, proven process after the rubbing seed against mesh and seed is pushed through the mesh opening and husk and kernel is separated.

An industrial duty machine, long lifetime ensured by rugged design ensures easily replaceable Impeller and hulling ring fabricated from a highly durable steel for wear resistance.

After Hulling Operation:

Spelt Huller removes the hull/husk of Spelt/Oat/Einkorn output of machine **Spelt Husk**, **Spelt Kernels** and **Spelt In husk** (none hulled) exists together. To obtain **Spelt Kernels** there is sequence to do the separation of **Spelt Husk**, **Spelt Kernels** and **Spelt In husk**. Your Sales representative will be happy to explain you what machines are used to obtain the expectable Kernel output.

Food Grade:

Easy access to all parts of the machine.
Food Grade painted surface is sufficient for Almond Seed processing equipment. Stainless Steel surface is optional.
Food Grade Lubricants for bearings.

Shelling yield:

Shelling yield ranges from 80 to 95 %, this high variation happens due to right conditions being provided or not and we are happy to share our experience. Please consult your sales agent.

Shipment:

If you are looking for single machine, we provide the Cargo parameters for each machine, so buyer can calculate Transport cost to delivery address and we will be more than happy to assist you in this matter please feel free to consult your sales agent.

Installation:

We supply technical documents and easy install videos to our clients for safe handling.
As well as our motto is 'Plug and Play' that makes our buyers experience much easier with Spelt Hulelr.

After Sales Support:

We have 7/24 online and on call After Sales Support Department.

For After sales parts purchasing you can go to our online **saattechnologe.com** or download **our App** to order your required spare part, if we have not opened an account for you, please go ahead open your account, purchase your part and it will get it delivered to your address.

Note: Capacities may vary for different impurity, moisture contents and seed verity.

ENVIRONMENTAL CONDITIONS

Environment Indoors
Temperature from -10°C to +40°C
Altitude Up to 1 000 m

NOISE

Sound pressure level, empty 79.2 dB(A)

MODEL	SP-250	SP-500
CAPACITY up to	500 kg/hr	1.0 tph
MOTOR kW	up to 5	up to 11
NOISE LEVEL	75-85 dB(A)	75-85 dB(A)
Net Weight KG	175	200

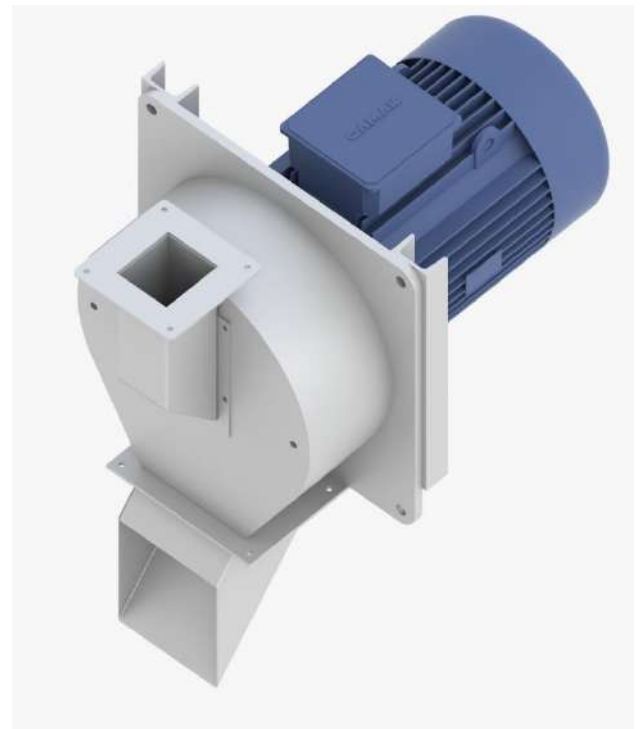

Saattechnologe.com | The right to alterations is reserved.

**Saat Technologie S.R.L. | Bucharest Tower Center, 22nd Floor 15-17 Ion Mihalache Blvd.
Sector 1, Bucharest 011-171 | ROMANIA | +40 744 578 303| info@saattechnologe.com**