

General

Brand	Saat Technologie
Designation	Almond Sheller
Model	AS 220
Use	Food Processing Industry
Application	Processing of Cereal grains and other seeds.

Almond Sheller is a precise and efficient sheller unit applicable for Almond in shell.



Conditions before Shelling:

Almond Nut to be shelled, should have been cleaned from outer dry pulp & separated from admixtures*
For optimum hulling yield, your sales representative will explain you in detail required conditions.

Shelling Operation with Almond Sheller: Nuts is fed into the hopper and from hopper 2 Vibratory Linear feeders with VFD feeds Almond to the Sheller Cylinder. Shelling Drum forces the Almonds to pass through the grates where shelling occurs. For best yield Sizing of Almond Nut is required due to Shelling Grates being fixed sizes. Multilabel Shellers used for higher capacity operations.

An industrial duty machine, long lifetime ensured by rugged design ensures easily replaceable Impeller and hulling ring fabricated from a highly durable steel for wear resistance.

After Shelling Operation:

Almond Sheller breaks the shell of Almond Nut and output of machine **Almond Shell, Almond Kernels** and **Almond In shell** (none sheller) exists together. To obtain **Almond Kernels** there is sequence to do the separation of **Almond Shell, Almond Kernels** and **Almond In shell**. Your Sales representative will be happy to explain you what machines are used to obtain the expectable Kernel output.

Food Grade:

Easy access to all parts of the machine.
Food Grade painted surface is sufficient for Almond Seed processing equipment. Stainless Steel surface is optional.
Food Grade Lubricants for bearings.

Shelling yield:

Shelling yield ranges from 80 to 95 %, this high variation happens due to right conditions being provided or not and we are happy to share our experience. Please consult your sales agent.

Shipment:

If you are looking for single machine, we provide the Cargo parameters for each machine, so buyer can calculate Transport cost to delivery address and we will be more than happy to assist you in this matter please feel free to consult your sales agent.

Installation:

We supply technical documents and easy install videos to our clients for safe handling.

As well as our motto is 'Plug and Play' that makes our buyers experience much easier with Almond Sheller.

After Sales Support:

We have 7/24 online and on call After Sales Support Department.

For After sales parts purchasing you can go to our online saatechnologie.com or download our App to order your required spare part, if we have not opened an account for you, please go ahead open your account, purchase your part and it will get it delivered to your address.

Note: Capacities may vary for different impurity, moisture contents and seed verity.



ENVIRONMENTAL CONDITIONS

Environment Indoors
Temperature from -10°C to +40°C
Altitude Up to 1 000 m

NOISE

Sound pressure level, empty 79.2 dB(A)

Available Options

- An effective shell separation can be achieved with Shell Blower Fan located at the outlet of the Almond Sheller.

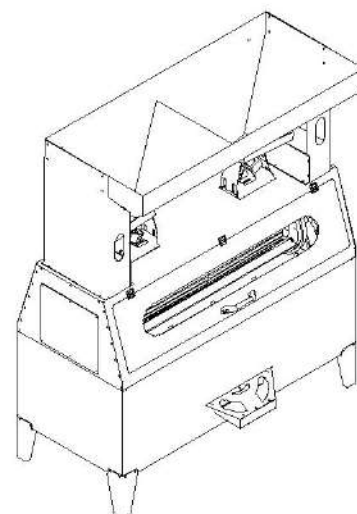
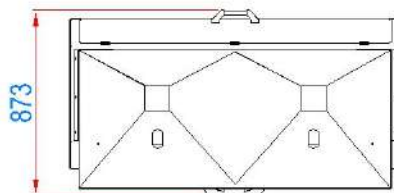
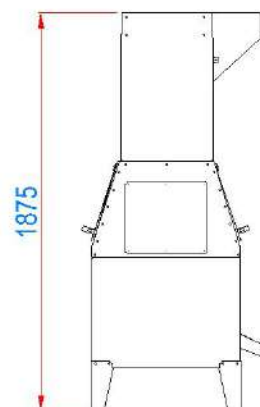
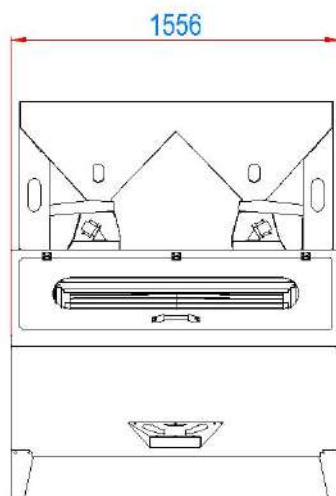

MODEL	AS-220
Width	873
Length	1556
Height	1875
Weight	500
Motor	0,75 kW
Capacity Almond	100kg/hr