

ROTARY DRUM SEED CLEANER

Saat Technologie Drum Seed Separator are used for cleaning Seeds such as barley, wheat, corn, oats, rice, soy, sunflower, canola, and legumes. Slight foreign matters are cleaned through aspiration. The product goes through the sieve holes of various diameters Large foreign matters come out of the drum end. Thanks to cleaning, unwanted materials such as stalk, straw, wood chips, corn cob pieces, garbage do not damage other equipment. Applications like such as rough cleaning, precision cleaning, seed cleaning and grading etc. can be performed for cereal and leguminous seeds. The product flow is better due to the continuous rotational motion. It is more sensitive and lighter than Vibro sieves, and its maintenance is easy. The sieves have a self-cleaning feature. It is capable of separating large foreign matters without clogging the sieve's inlet and outlet. With their unique design and strong structure, Saat Technologie drum sieves provide high efficiency and low energy consumption. Hole diameters depend on the product. Sieve can be replaced rapidly from easy-to-open side cover. The sieves clean themselves during sieving via wooden rollers. Drum angle can be adjusted according to the foreign matter in the product to be sieved, and the angular adjustment is made by a manual or motorized movement mechanism. The rotational speed of the drum can be adjusted electronically. During operation, sorting can be controlled by taking samples from the control points.

FEATURES

- Full Bolt Joint, Easy-to-assemble Body Structure
- Maximum Endurance
- High Productivity, Low Energy Consumption
- Sieve Selection Based on Product Type
- Easily Replaceable Sieves
- Speed Controlled Drum
- Fan, Cyclone (Optional)
- Jet Filter (Optional) By-Pass Line (Standard)

SAFETY

- Cover Safety Sensor (Standard)

DRIVE SYSTEM

- Hollow shaft for reducer motor (Standard)
- Drum Speed Control (Standard)
- Drum Angle Control via Manual Mechanism (Standard)
- Drum Angle Control via Motorized Mechanism (Optional)

ACCESSORIE

- Input Module
- Output Modules
- Sieve Cleaning Rollers
- Sampling Apparatus
- Sieve Sheet Replacement Apparatus (Optional)

Pre-Cleaning with Aspiration

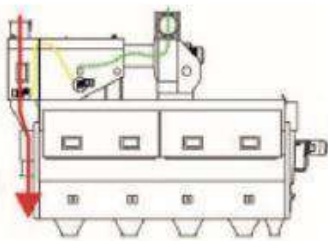

Rough Pre-Cleaning

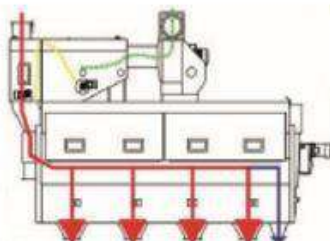

Cleaning

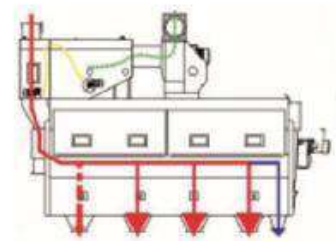

Precision Cleaning

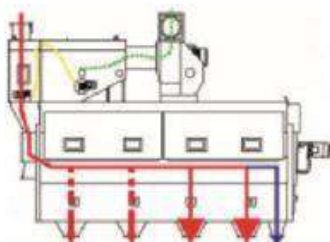

Grading

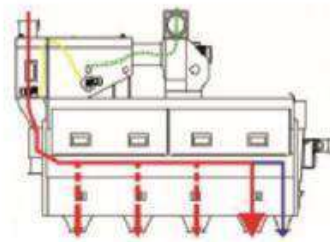

CAPACITY AND DIMENSIONS

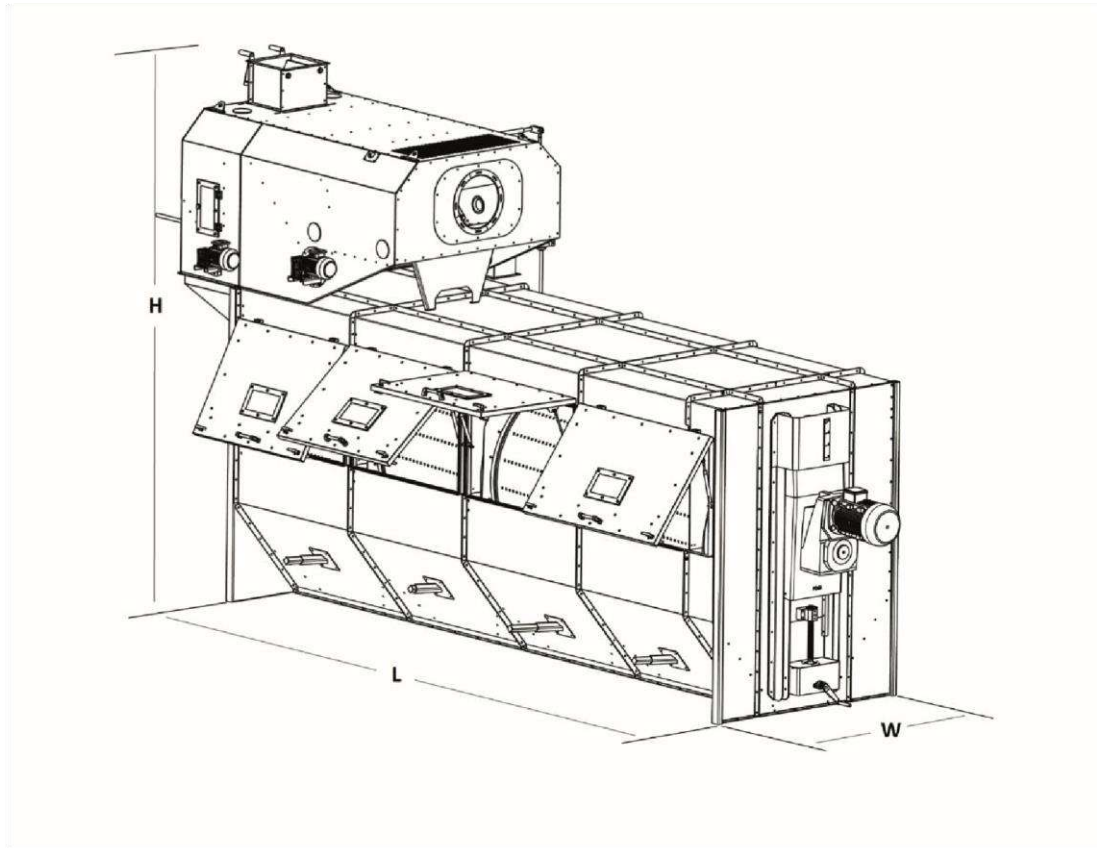

MODEL	Number of Sieves	Drum Diameter	Drum Motor Power	Rough Pre-Cleaning	Precise Cleaning	Length L (mm)	Width W (mm)	Height H (mm)
SDC553	3	Ø550	1,1 Kw	6,5 t/h	5,5 t/h	2300	650	800
SDC554	4	Ø550	1,5 Kw	8,5 t/h	7,5 t/h	2800	650	800
SDC653	3	Ø650	1,5 Kw	30 t/h	15 t/h	3100	850	1300
SDC654	4	Ø650	1,5 Kw	35 t/h	25 t/h	3800	850	1300
SDC853	3	Ø850	2,2 Kw	75 t/h	55 t/h	4600	1000	1700
SDC854	4	Ø850	4 Kw	95 t/h	75 t/h	5700	1000	1700
SDC1303	3	Ø1300	5,5 Kw	150 t/h	115 t/h	5100	1550	2300
SDC1304	4	Ø1300	7,5 Kw	200 t/h	150 t/h	6250	1500	2300
SDC1305	5	Ø1300	11 Kw	250 t/h	200 t/h	7300	1550	2300

The above-mentioned values apply to the cereals and granular matters of which bulk density is 0,75 / m3. Designs and dimensions are subject to change without notice.