

# OPTIMUM 202

## SUPER FINE SEED CLEANER

Designed for high quality fine cleaning of seeds, malting barley, legumes, grains and garden seeds.

The unique air lifting unit makes the Optimum Super 208 ideal for the most challenging separations. The Super fine cleaner includes **shaker feeder, pre-suction and after-suction system, electronic control system, flexible screen flow and air lifting fan.**

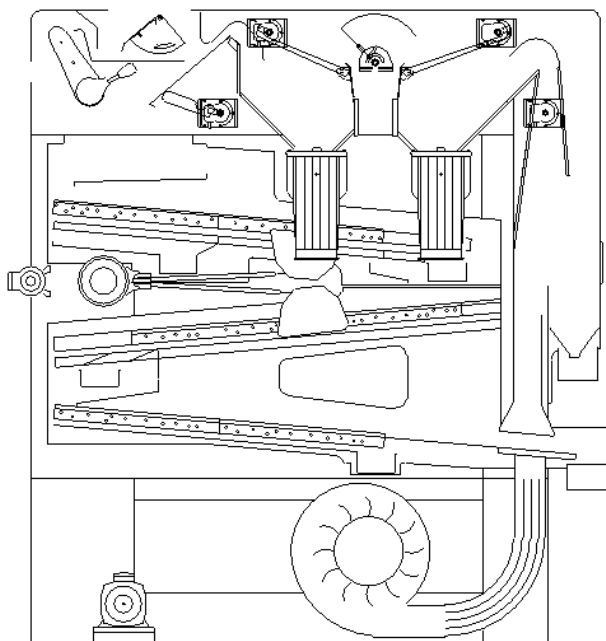

SEEDS	Bulk density t/m <sup>3</sup>	Moisture content %	Capacity t/h
Barley	0.68	14	2.2
Clover	0.82	14	1
Coffee, green	0.65	14	2
Maize	0.71	14	1.5-2
Oats	0.51	14	1.5
Peas, common	0.7	14	2
Rapeseed	0.74	7-9	1.5
Rice, paddy	0.51	14	1.5
Rice, white	0.75	14	2
Rye	0.69	14	2.2
Ryegrass	0.3	14	0.4
Sorghum	0.64	14	2.2
Soybeans	0.72	14	2
Sunflower	0.4	7-9	1
Wheat	0.76	14	2.5

Note: Capacities may vary for different impurity and moisture Contents

### SCREENS

Screen angle	5.0 Degrees
Screen area, total	3 m <sup>2</sup>
Screen size	625x800 mm (6 pcs)

### DIMENSIONS

Overall length	3 025 mm
Overall height	3 110 mm
Overall width	1 300 mm

### WEIGHT

Weight, empty	1 950 kg
Weight, operating (wheat)	1 990 kg
Weight, choked (wheat)	3 100 kg

### OPERATING SPEED

Shaker feeder (shaft)	140-700 rpm
Screens (shaft), fixed speed	280-285 rpm
Screens (shaft), variable speed	260-320 rpm
Aspiration fan,	65-750 rpm

### ELECTRICAL RATINGS

Motor, shaker feeder	0.75 kW
Motor, screens	1,5 kW
Motor, aspiration fan	1.5 kW
Control panel	110-230 V

### AIR SUPPLY AND EXTRACTION

Aspiration volume	4 500 m <sup>3</sup> /h
-------------------	-------------------------

### DYNAMIC LOADS

Horizontal load "Ph"	±745 N @ 4.6-4.8 Hz
Vertical load "Pv1" (inlet end)	±305 N @ 4.6-4.8 Hz
Vertical load "Pv2" (outlet end)	±305 N @ 4.6-4.8 Hz

Note: Dynamic loads are for normal operation.

### NOISE

Sound pressure level, empty	79.3 dB(A)
-----------------------------	------------

### COMPLIANCE

EU machinery legislation	Yes
EU ATEX legislation	Option*
EU food contact legislation	Option*

\* Consult your **Saat Technologie** dealer for full details.

### ENVIRONMENTAL CONDITIONS

Environment	Indoors
Temperature	From -20°C to +40°C
Altitude	Up to 800 m

### SURFACE PROTECTION

Frame and enclosure	Paint (corrosivity category C2; low durability)
---------------------	---

### LIFETIME

Intended life limit	20 years
---------------------	----------